

LAN Transformer

100/1000 BASE-T ES24701KPTG Equivalent to SM51589PEL

REV: 0

A. MECHANICAL(unit:mm)

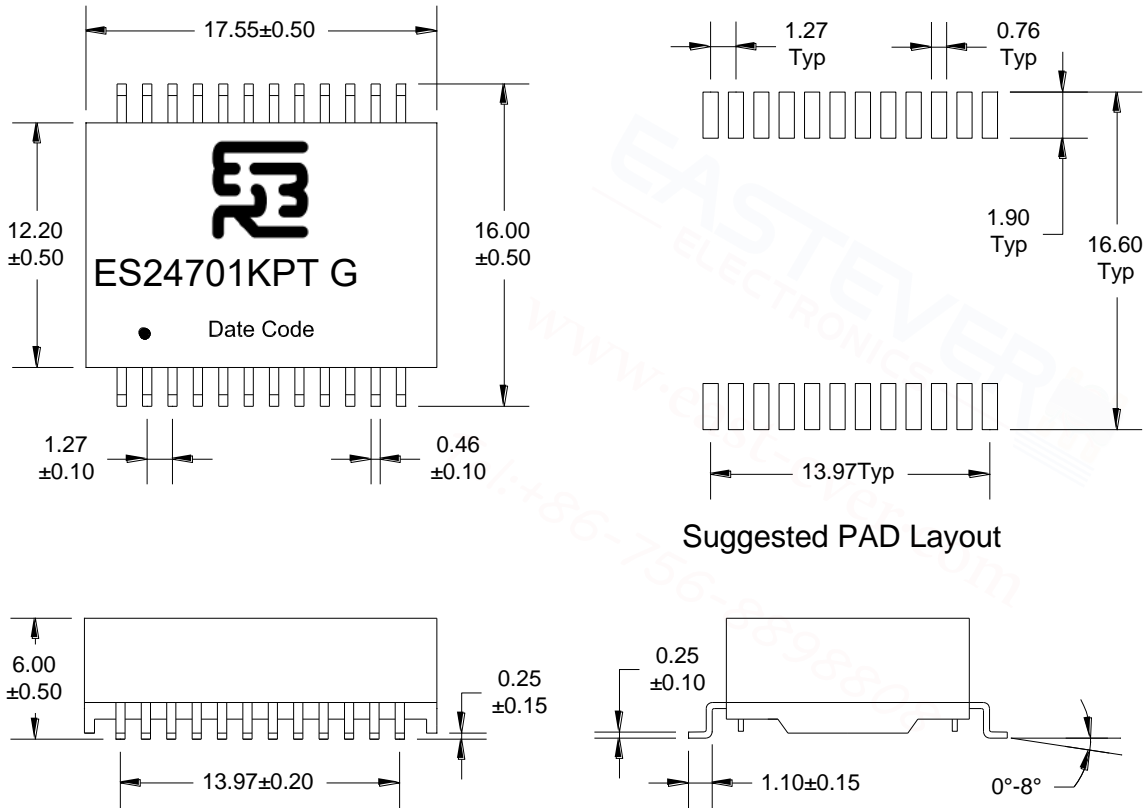

B. SCHEMATICS

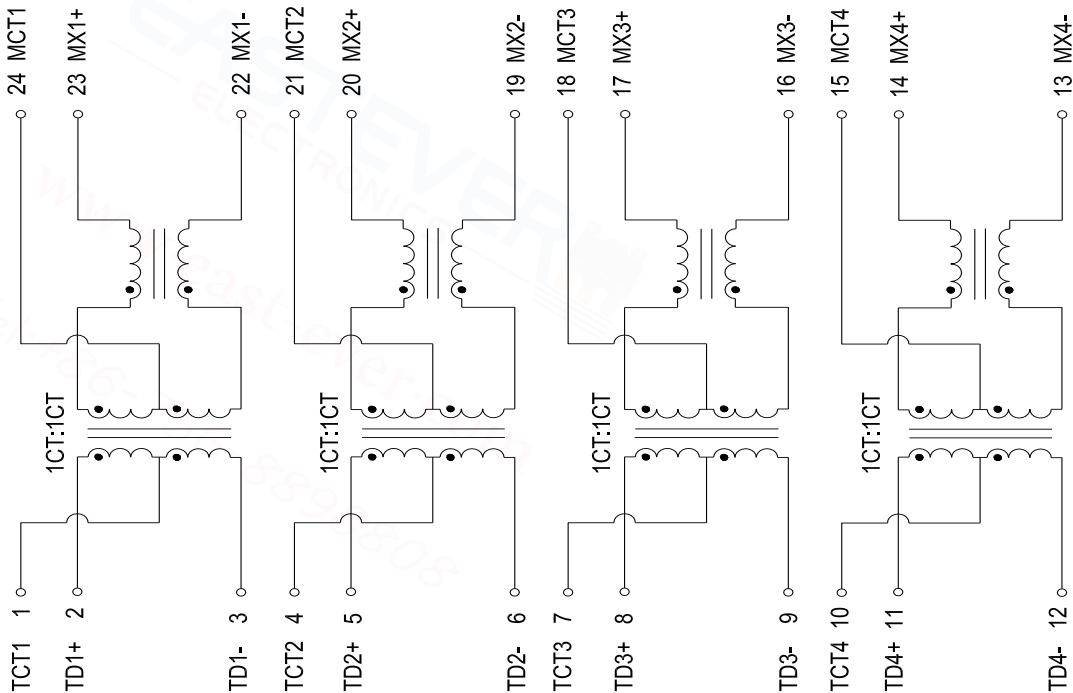

LAN Transformer

100/1000 BASE-T ES24701KPTG

REV: 0

C. ELECTRICAL SPECIFICATIONS @25°C

1. OCL: 350uH Min @ 100 KHz, 0.1V 8mA DC BIAS
2. Leakage Inductance: 0.5uH Max @ 100KHz, 0.1V
3. DCR: 1.4Ω Max
4. Turns Ratio: 1CT:1CT±5%
5. Insertion Loss: -1.2 dB Max @ 0.5-1 MHz
 $-0.2-0.002*f^{1.4}$ dB Max @ 1-125 MHz
6. Return Loss: -16 dB Min @ 1-40 MHz
 $-10+20*\log(f/80)$ dB Min @ 40.1-100 MHz
7. Cross Talk: -30 dB Min @ 1-100 MHz
8. Common Mode Rejection: -30 dB Min @ 1-100 MHz
9. Isolation Hipot: 3000VAC 1mA 2S
10. Operating temperature -40°C to +95°C
11. Storage temperature -40°C to +125°C
12. IEEE802.3at compliant performance

D. PACKAGE INFORMATION

Package Quantity:

One Reel=350Pcs

One Inner Carton=350*2=700Pcs

One Export Carton=700*5=3500Pcs

